

Wayside Railroad Lubrication System

Lincoln, the #1 Worldwide Lubrication System Supplier, is Driving Technology to Meet the Railroads' Requirements in Demanding Environments



The Challenge

- **High lubricator maintenance costs**
- **Uncontrolled and uneven grease placement**
- **Too many weather and temperature variants**

Other lubrication systems apply large, uncontrolled amounts of grease in short durations to the rail. These systems flood the rail even when set at their smallest time setting. Any grease that does not attach to the wheel, falls to the ballast resulting in wasted material and uneven distribution at the application site.

The Lincoln Wayside Lubrication System effectively applies a consistent volume of grease to the rail and it holds that grease in place allowing the wheels to grab and carry it around the length of the track curve.

Precisely Apply Small Amounts of Lubricant Frequently

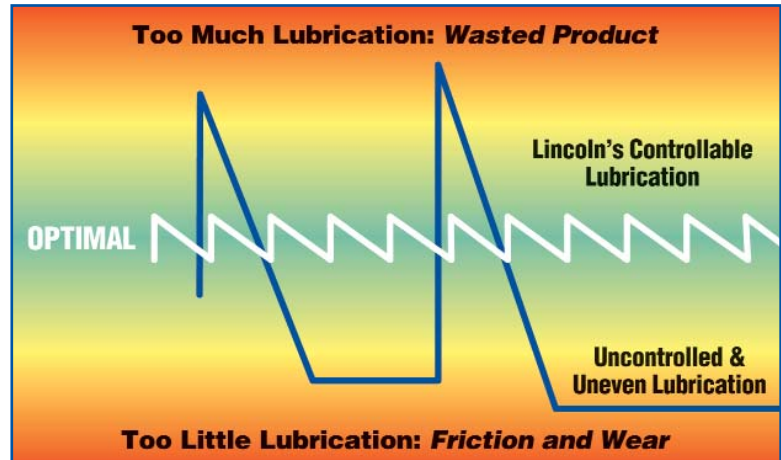

The Lincoln Solution

Positive Displacement Utilizing Lincoln's Patented, Field-Proven Technology

Precisely controlled, even grease output to each rail regardless of lubricant viscosities and temperatures is achieved with Lincoln's Wayside Lubrication System.

Lincoln's Patented SSV® Divider Block

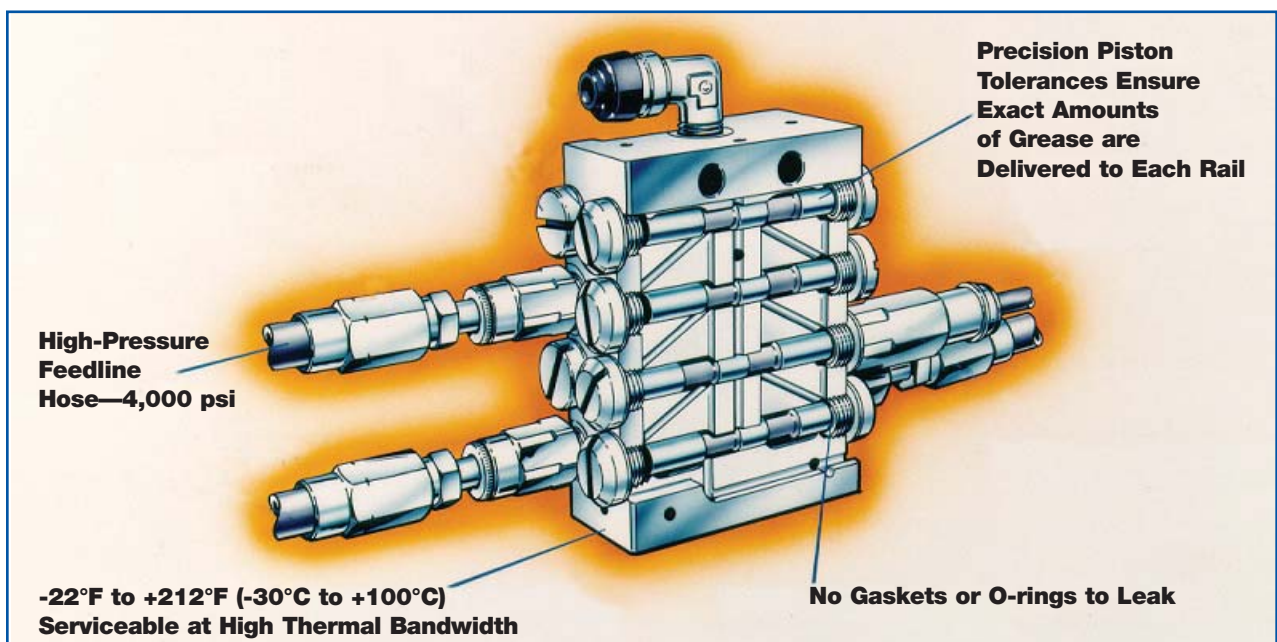

The Results

Features and Benefits



Reduce Lubricant Cost

- Small, precise amounts of grease
- Output in frequent intervals for the most efficient lubricant usage
- Even distribution to every wiper bar outlet
- Pump speed adjustable to further fine-tune the lubricant output
- Wiper bar places grease high on the gauge face to be carried by passing wheel flanges avoiding grease migration to the top of rail

Minimize Maintenance Costs and Time

- Wiper bar tucked under rail to avoid wheel strikes
- High-pressure system prevents clogged outlets

Performs in All Weather and Seasons

- 24VDC system with low current draw to maximize storage capacity and power
- Oversized solar panel holds charge during long periods of cloudiness
- High-pressure system continues to pump and distribute grease in extreme temperatures
- IP6K-rated high-density polyethylene reservoir keeps moisture out

Reduce Total Cost of Ownership

- System designed to withstand harsh environments to lower maintenance costs
- More consistent rail and wheel lubrication

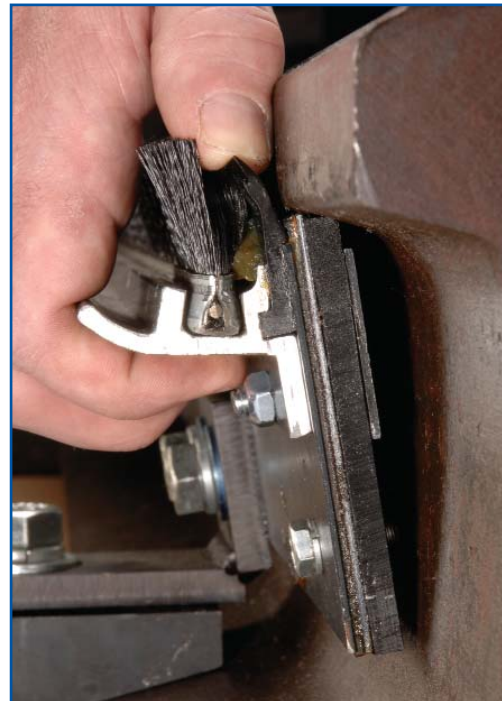

System Components:

- **SSV Divider Valve**—Patented, field-proven divider blocks deliver equally measured grease outputs to each rail
- **FlowMaster® Pump**—High-pressure, 24 VDC two-stage pump proven in harsh industrial applications
- **Grease Output Controller**—Select the pump “on” time and the activation wheel count with easy-to-adjust dials. An LED indicates that the sensor is detecting passing wheels. An axle counter is also included to monitor the number of axles that have been sensed
- **Wheel Sensor**—Shielded with a cover to protect against damage from debris or ice

Lincoln Wayside Lubricator

System Specifications

Operating Voltage Solar/Battery System: 24VDC, 140W
 Electric System: 90-250VAC

Operating Temperature -40°F to +160°F
 (-40°C to +70°C)

Operating Pressure 4,000 PSIG
 (276 Bar) Maximum

Grease Reservoir 800 Lbs Capacity
 (110 Gallons or 416 Liters)
 IP6K-Rated

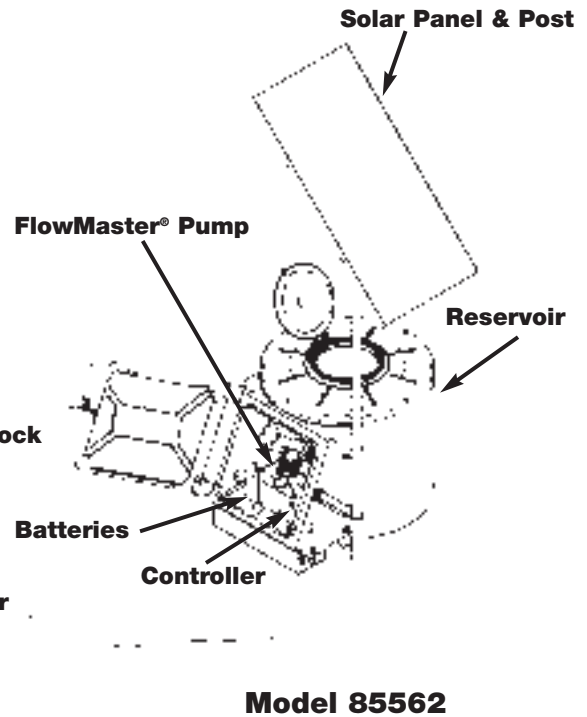
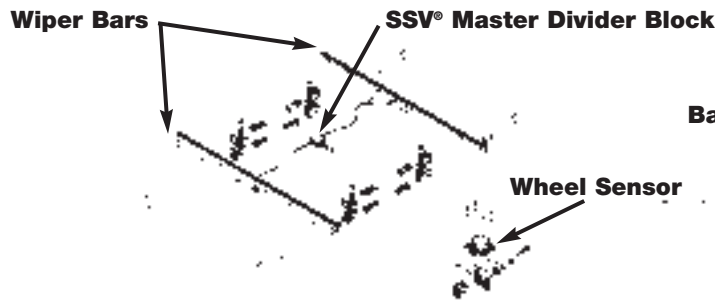

Lincoln Railroad Retrofit Kit (Model No. 85476)

Upgrade Your Hydraulic/Mechanical Wayside Lubrication System to Lincoln's High-Pressure Electric System

- **Precise:** Lubricant dispenses as soon as rail wheels are sensed—no delay for hydraulic pressure build-up
- **Reliable:** Exact adjustment of pump “on” time for precise quantity of lubricant dispensed without waste
- **Versatile:** Lincoln’s upgrade kit is easy to install and conveniently fits into your existing pump housing system
- **Optional Assemblies:** Add Lincoln’s wiper bars for a complete distribution system of grease to the rails

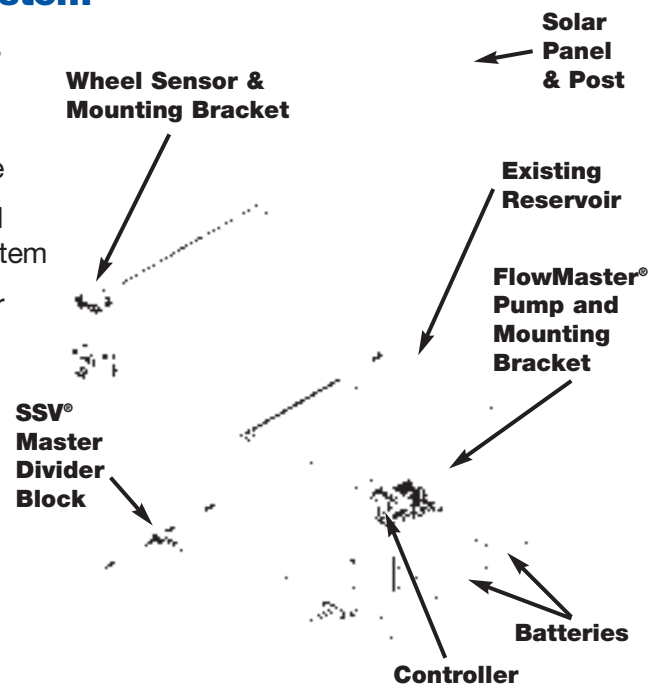

Available Wayside Systems

Model	Description
85562	Single track 24VDC solar
85563	Dual track 24VDC solar
85564	Single track VAC electric
85565	Dual track VAC electric
85476	Upgrade Retrofit Kit

Industry Leader

Continually satisfying our customers with the world’s best lubrication equipment and pumping systems has made Lincoln the largest and most successful company in our field. For more than 90 years, companies have relied on our technical and quality leadership; our world-class manufacturing and customer service; and our vast network of distributors and support facilities.



Lincoln Industrial Corp.
 One Lincoln Way
 St. Louis, MO 63120-1578

Phone (314) 679-4200
 Fax (314) 679-4359
www.lincolnindustrial.com

Form 442998 (5/05)
 © Copyright 2005
 Printed in USA